



Automation solutions for pulp and paper

Enhance the value generated by your mill

Vision: To enhance your mill's productivity

Complete solutions to match your needs

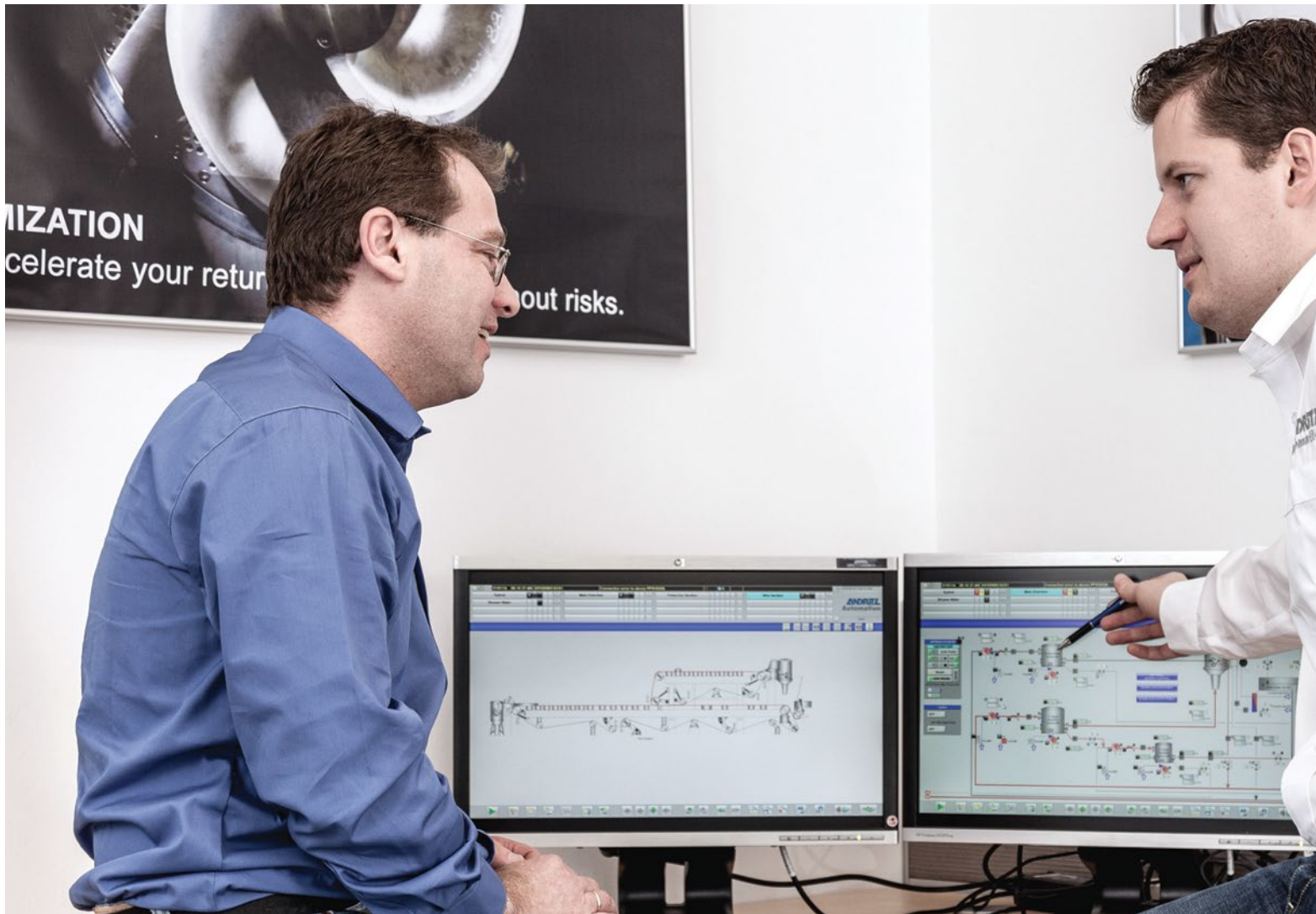

The ANDRITZ vision is to streamline project execution and optimize operations at your mill, enhancing your mill's value generation and establishing a win-win relationship between you and ANDRITZ.

Mills engage ANDRITZ AUTOMATION for a variety of project services including front-end planning, project engineering scoping, site E&I/P&ID audits, cost estimations, and ROI payback justification. ANDRITZ' value-focused and cost-effective approach combines pulp & paper process knowledge with leading technologies, quality engineering,

and hardware to create a complete and tailored solution for your mill.

Why are pulp & paper companies that utilize ANDRITZ AUTOMATION successful? ANDRITZ makes a commitment to technical performance, schedule, and price, and then delivers on that commitment.

Mills have the freedom to combine systems and technologies from different vendors and platforms through the OEM-discounted pricing that ANDRITZ AUTOMATION offers on all controls, electrical, power, and

instrumentation systems. You can take advantage of the best available technologies and the most appropriate innovations, and ANDRITZ AUTOMATION technicians will skilfully integrate them to create a single, comprehensive system.

Mills that work with ANDRITZ AUTOMATION enjoy continuous improvement projects and 24/7 on-call service and support for all PLC/DCS/HMI/SCADA, instruments, electrical, and power systems. Working with ANDRITZ will enhance the productive value of your mill.



ANDRITZ AUTOMATION's global presence

109 locations with automation competence

Over 2,000 employees in automation

- Process control
- Electrical engineering
- Instrumentation
- Power engineering
- Process simulation modeling
- Autonomous process management
- Remote control
- Project development
- Project management
- Support and continuous improvement

"We have done several projects with ANDRITZ AUTOMATION in the past five or six years. Each time, the quality of work and flexibility in meeting our requirements has been excellent. They have a strong team who really understand power and electrical generation."

Graham Cant, Harmac Pacific, B.C.



Key products and capabilities

Release the full potential of your mill



IDEAS simulation for design

Process modeling simulation is valuable for everything from preliminary design through to high-fidelity simulation of your entire process.

Used for: Optimizing sizing, integrating keystone unit processes, developing control narratives, validating process control logic, and operator training.



PrimeControl

An integrated process control solution featuring the critical elements that make your process management, operators, and process control systems effective.

Includes: ANDRITZ process and equipment knowledge, multi-platform DCS/PLC/HMI/SCADA integration, instrumentation, system architecture, E&I engineering, commissioning and support.



PrimeDrive

A comprehensive solution that combines coordinated machine drive systems, Multi-Motor Drives (MMD), QCS, DCS, PLC, new systems, upgrades, and troubleshooting.

Combines: ANDRITZ expertise, multi-vendor systems, cost-effective hardware, configuration, project management and site services.

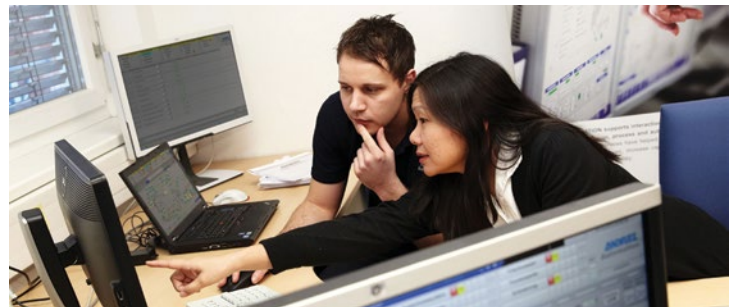

Operator Training Tools (OTS)

Training systems for skills/experience and knowledge, including Web/Computer-Based Training (WBT/CBT) and the Operator Training Simulator (OTS).

Typical training scenarios: Cold-start, hot restart, planned shutdown, emergency shutdown, alarm conditions, and custom scenarios.



Advanced controls and autonomous operation

The BrainWave model predictive controller and Advanced Control Expert (ACE) systems that autonomously optimize the process area based on cost and value.

Process areas: Bleaching ACE, Recast/Kiln ACE, RecBo ACE, Refiner ACE, Digester ACE, MDF-ACE, PaperMachine ACE, and more.



Burner Management and Safety Systems (BMS)

Specialty knowledge, cost effectiveness, and practical ability combined to ensure the safety of new and existing equipment.

Applicable safety standards: FM Global, National Fire Protection Agency (NFPA), ISO requirements, vendors hardware and interfacing standards.



Electrical Power Systems (EPS)

The design, optimization and engineering of power systems, from utility tie-ins, substations, and switchgear to site distribution and power management.

Expertise: Power system analysis, brownfield integration of power generation, energy efficiency audits, on-line monitoring, Arc flash and coordination studies, benchmarking, optimization, alerts.

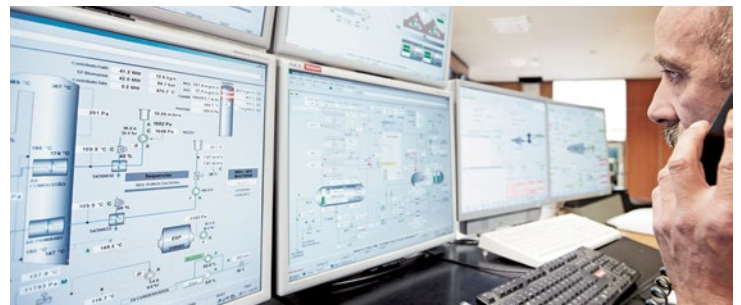

Support and improvement programs

A support network that includes on-call technicians, comprehensive long-term support, and continuous improvement programs.

Services: Dedicated DCS/PLC expertise; power, electrical, and instrumentation engineering; on-line reliability and performance monitoring, expert advice, and data analytics.

Key products and capabilities

Automation across your entire mill

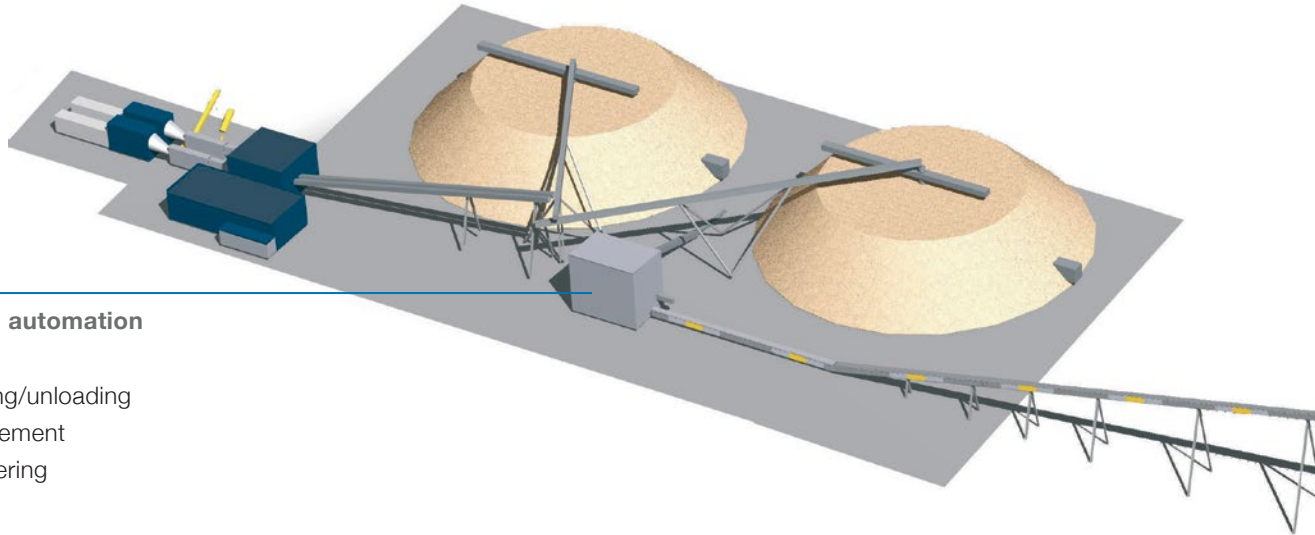

Materials handling automation

- Chip moisture
- Train/truck loading/unloading
- Inventory management
- Electrical engineering

Safety and Burner Management System (BMS)

Power system

- Utility tie-in negotiation
- System modeling
- Substation and switchgear
- On-site generation
- Energy audits and improvements
- Resource Management System (RMS)

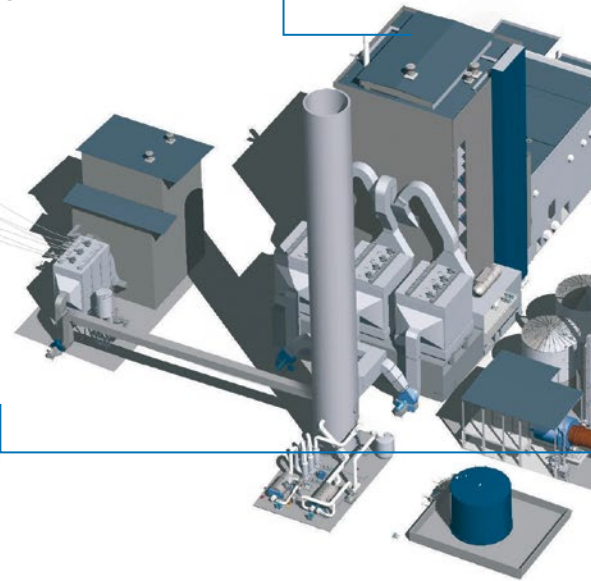

Power island ACE

- Kiln ACE
- Recovery boiler ACE
- Soot blowing ACE
- Evaporator ACE
- Steam network ACE

Automation integration

Electrical engineering

- System design and build
- Installation design and specification
- Installation management
- On-site commissioning

PrimeControl

- System architecture, hardware, programming, operator graphics
- ANDRITZ best practice process and technology knowledge
- Complete solution
- Carefully planned for mill downtime
- Commissioning and support

Support and improvement programs

- On-line analysis of mill process data
- ANDRITZ process and equipment experts
- Mill performance and reliability remote monitoring and data analytics
- ANDRITZ's value to the mill is incentivized based on mill's KPIs/KRAs

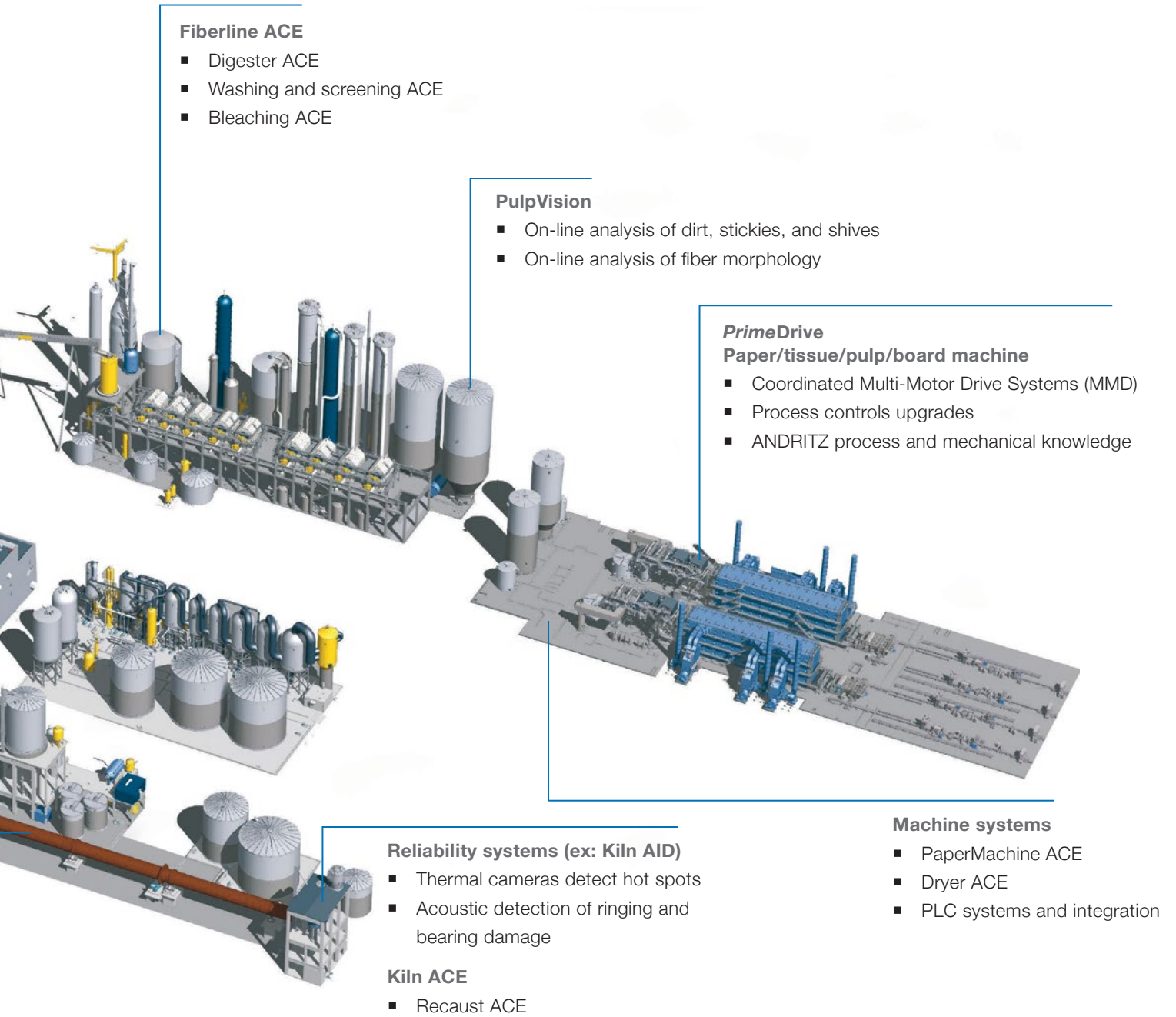

Autonomous operation and optimization

- Integration of control and data systems
- Fault tolerant control
- Enabling remote control

High-performance trained operators

- Knowledge management and transfer
- Skills training using Operator Training Simulator (OTS)
- Modular or fully customized process

Application case studies

Best practices and technologies



Pulp mill process performance and controls, USA

The challenge: To upgrade obsolete controls and provide a fiber line process control replacement, advanced controls, electrical engineering expertise, and operator training.

The action: ANDRITZ developed, scoped, and estimated the project by auditing the existing P&IDs, loop sheets, instruments, and historical data. The complete solution included three alternatives for DCS platforms (Honeywell, Foxboro, and Emerson) packaged with dynamic process simulation (IDEAS), BrainWave advanced process control, improved hardware and equipment, and ANDRITZ engineering expertise.

The result: Working to tight mill downtime requirements, ANDRITZ improved the mill's process performance, control logic, instrumentation, and autonomous optimizing controls.



Steam turbine generator, Canada

The challenge: To upgrade an operating mill from an old steam turbine generator (STG) to a new 25MW STG while balancing power demands and supplies.

The action: A dedicated team carried out the project, remaining hands on from start to finish and assuming turnkey responsibility for electrical, controls and power integration. ANDRITZ also negotiated the design with the power utility.

The result: Money was saved on protection design with utility and the project was commissioned on time with minimal mill downtime.

Multi-mill operator training system, Thailand

The challenge: To reduce delayed restarts and poor performance at six operating mills that were facing increased operator turnover partly due to the retirement of senior staff.

The action: ANDRITZ implemented an Operator Training System (OTS) based on a modular mill process relevant to all mills. It provided both centralized and remote web-based training for operators.

The result: This cost-effective approach to competency-based skills training resulted in faster start-up, shutdown, and recovery from problems. The improved efficiency increased mill capacity and lowered chemical costs.

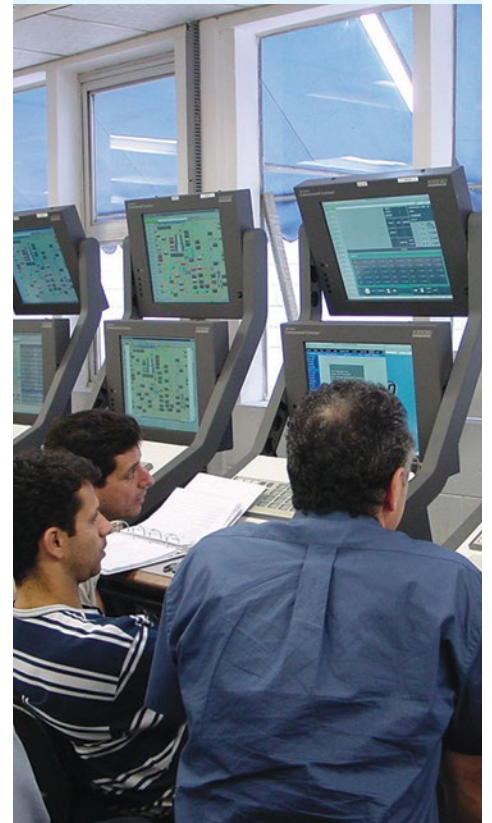

New pulp line and EPC scope, Brazil

The challenge: To design, build, and commission a new pulp line, including fiber line and recovery island, and realize performance and capacity targets on schedule and on budget.

The action: Packaged with ANDRITZ process equipment and EPC project delivery, the IDEAS high-fidelity process simulator model was used for P&ID validation, development of control narratives, and DCS and advanced process control logic checks. The accompanying operator training system (OTS) ensured that operators were well trained.

The result: Guaranteed capacity and performance improvements were achieved and exceeded. Start-up was quick and performance, high. Ongoing operations have been stable and reliable.



Kraft bleaching, USA

The challenge: To reduce the chemical consumption costs and the variability of final brightness for continuous changes in incoming kappa while optimizing processes, instruments, and advanced controls.

The action: The existing bleach area process was complex, with a four-tower (DO, EOP, D1, and P) design and limited reliable instrumentation. The process response was non-linear, with long dead time delays. ANDRITZ studied the process and existing performance, then developed and implemented a Bleach ACE solution that included instrumentation, DCS logic, advanced and regulatory controls.

The result: Significant operating cost reductions and reliable, stable brightness were achieved. The project realized a return on investment (ROI) payback of less than 12 months.

Paper mill controls and drives upgrade, Central Europe

The challenge: To upgrade obsolete, unreliable, and inefficient controls, instruments, and machine drives for a large operating mill. To integrate multiple vendor systems and work with difficult-to-engage local installation contractors.

The action: ANDRITZ developed, scoped, and estimated a well-planned multi-year upgrade program with clear technical specifications — a turnkey packaged scope. The upgrades, handled by a dedicated project team, combined ANDRITZ's *PrimeControl* (DCS, HMIs, MCCs, and instrumentation) and *PrimeDrive* (machine drives) technology.

The result: Unexpected problems from installation contractors were handled efficiently, ensuring that upgrades were completed on schedule and on budget. It proved a cost-effective package, with ANDRITZ OEM pricing offered on hardware when provided as a turnkey solution.



Life cycle phases

Creating value for any and all mills

Automation is like the central nervous system of your mill; it touches every part of your operation from process performance to quality, reliability, and safety, and is critical to your success. Automation differs from mechanical, civil, or process engineering skills. To ensure success, engage a specialty automation company that will design an integrated system, develop it with you, and support you long term.

Design & build

Get it done with ANDRITZ AUTOMATION — on budget, on time, and on quality. ANDRITZ can take complete responsibility for designing, building, commissioning, training, and supporting your electrical, power and process control systems.

Customize

Your mill is unique, and likely combines some old hardware and some new, as well as multiple system platforms from multiple vendors. ANDRITZ AUTOMATION has the skill to work with that, and can develop a customized solution for further enhancement.

Innovate

All appropriate technical innovations will be yours with ANDRITZ AUTOMATION. Through global engagement with technology vendors, ANDRITZ has access to the latest equipment and newest methods for system communications, analysis, and response.

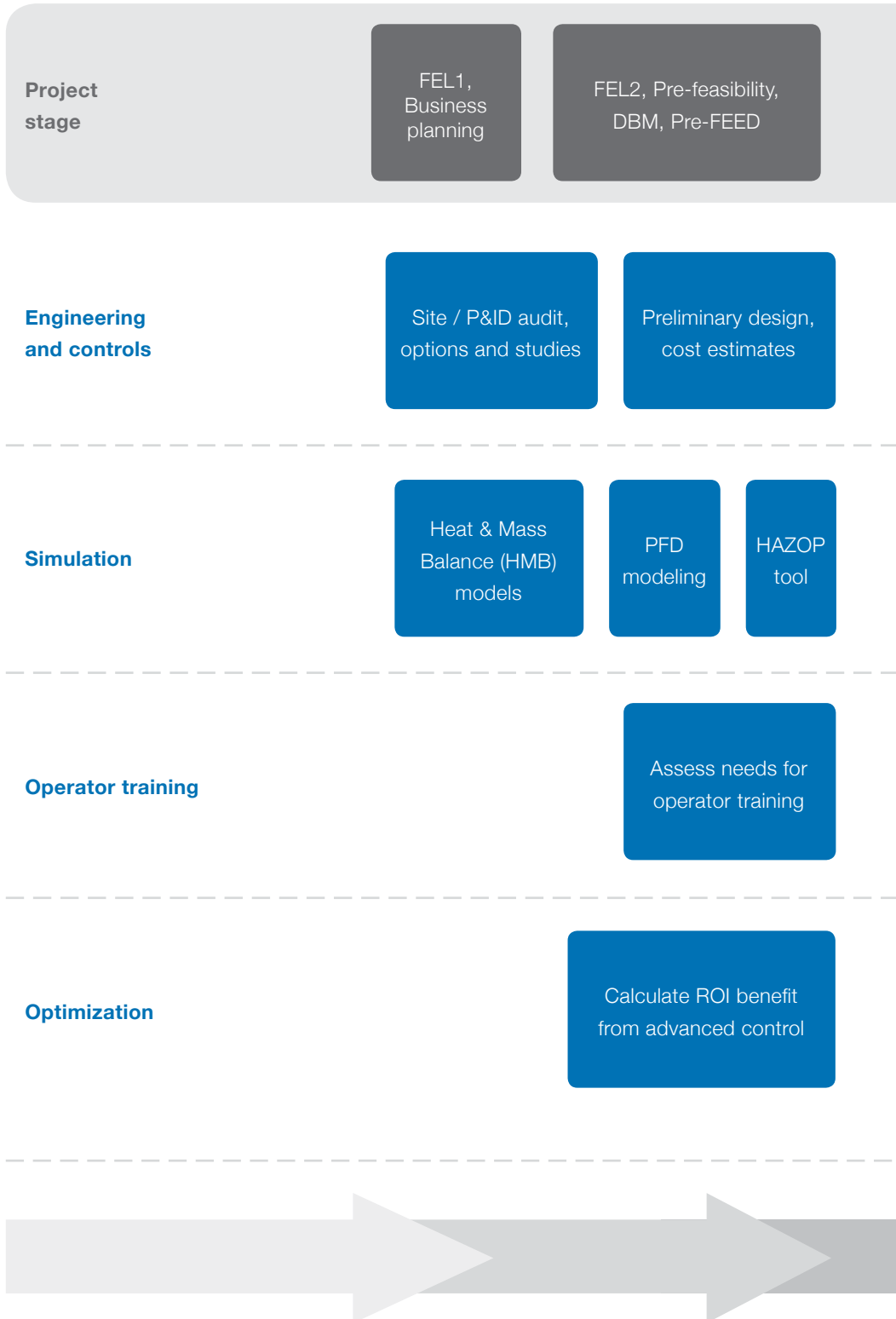

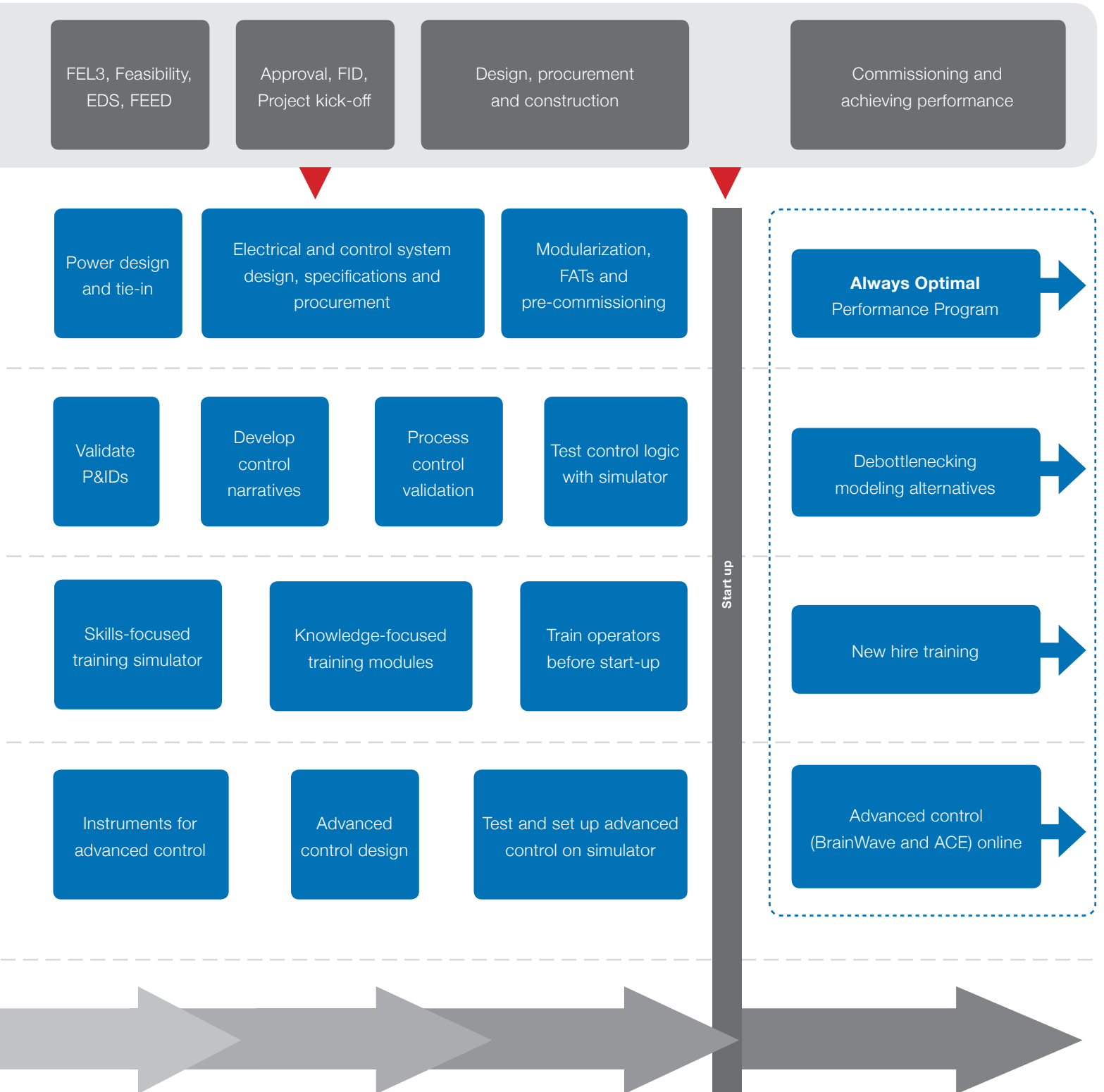



ANDRITZ Inc.

Atlanta, GA, USA

Phone: +1 (404) 370 1350

Austria: Vienna | Brazil: Belo Horizonte, Curitiba | Canada: Nanaimo, Prince George, Richmond, Terrace

Chile: Santiago | Finland: Kotka, Tampere, Varkaus | India: Bangalore | USA: Bellingham, Montoursville

www.andritz.com
automation-sales@andritz.com